

2. SETTING UP THE 144 J & L FOLDER GLUER FOR A PRODUCT CHANGEOVER

- a. Place the machine in **(ESP) ENERGY SAFE POSITION** (see section 2.b.).
- b. The operator takes a sheet of corrugated from the next order and folds it (fig. 2-1).

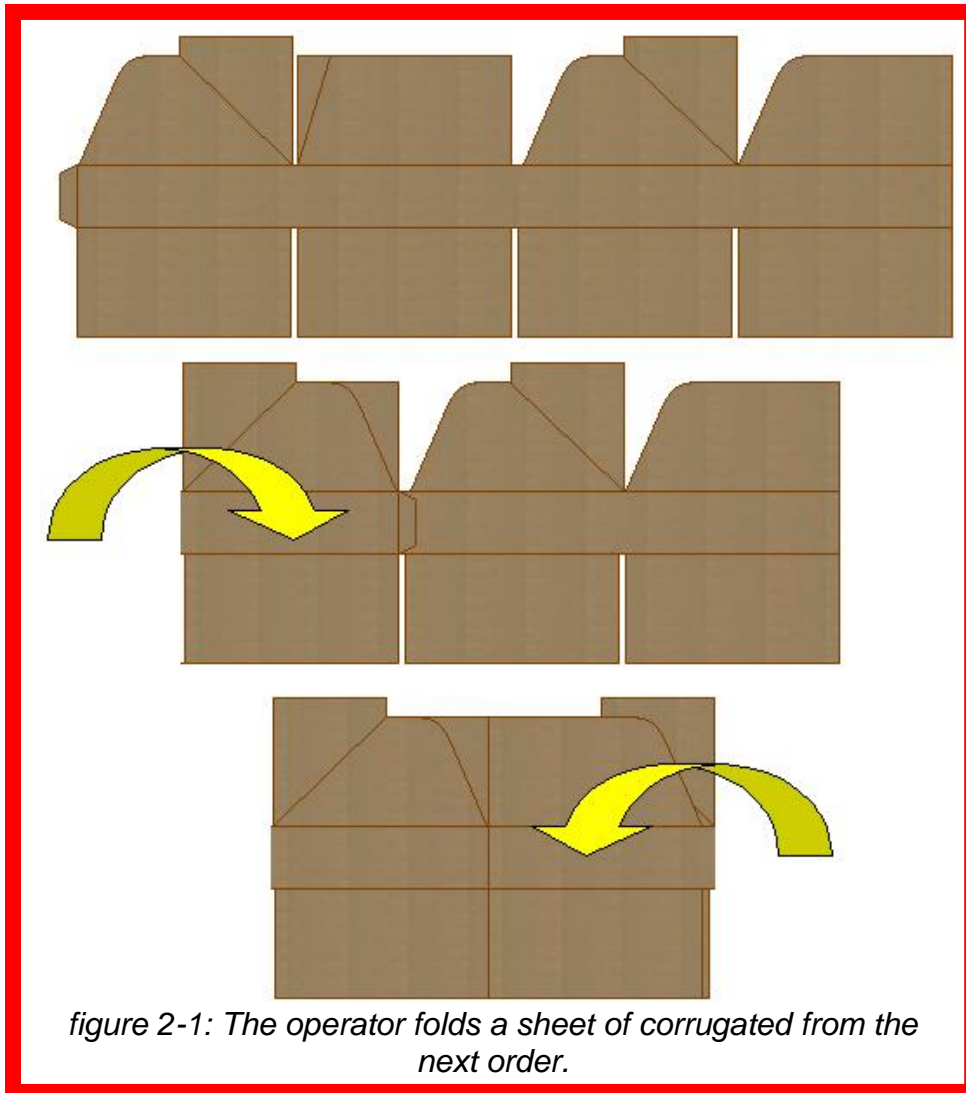

- c. The operator determines the centerline of the folded corrugated and lines it up with the yellow **CENTERMARKERS** on the

MODULE 1000 FEED SECTION (fig. 2-2).

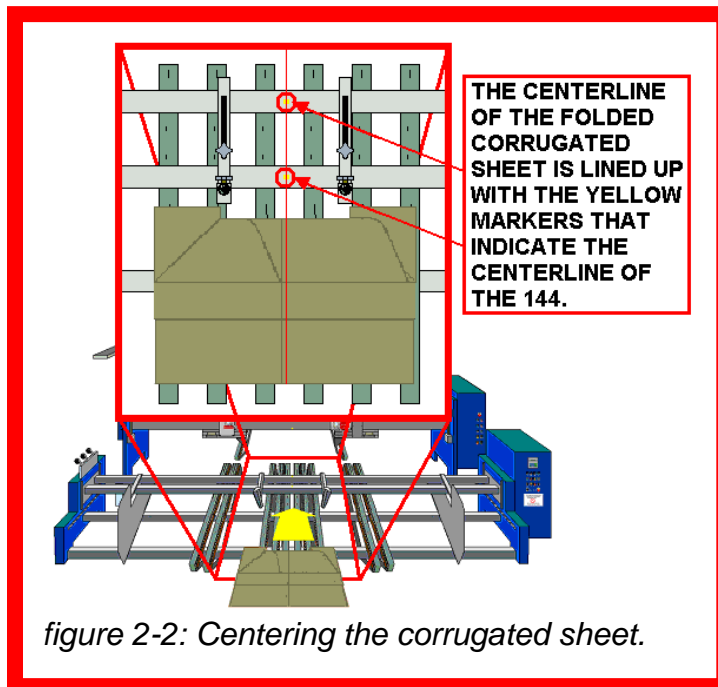

- d. The operator unfolds the corrugated sheet while keeping it in place (fig. 2-3).

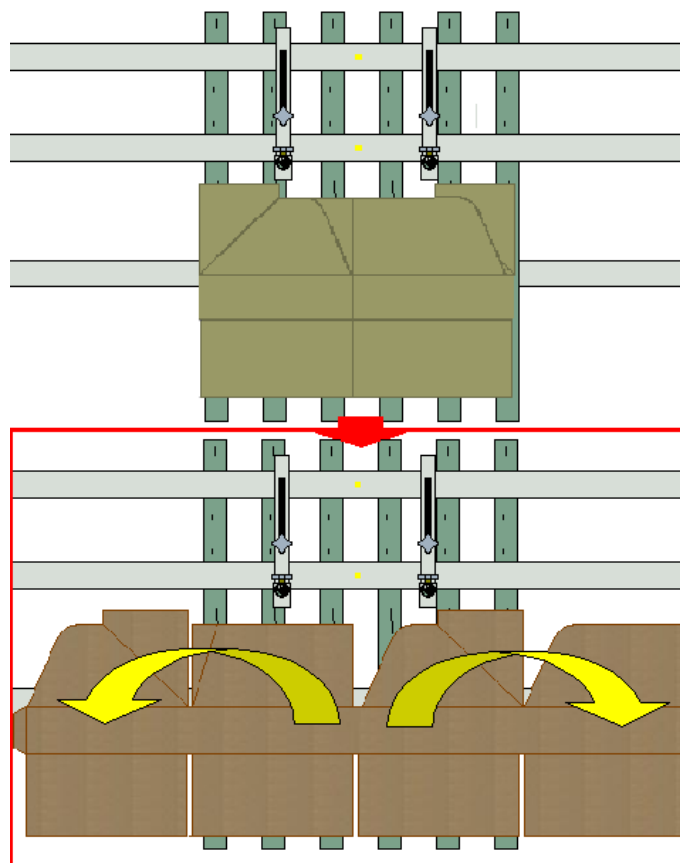

- e. The operator adjusts the **INFEED GUIDE PANELS** to the size of the corrugated sheet (fig. 2-4).

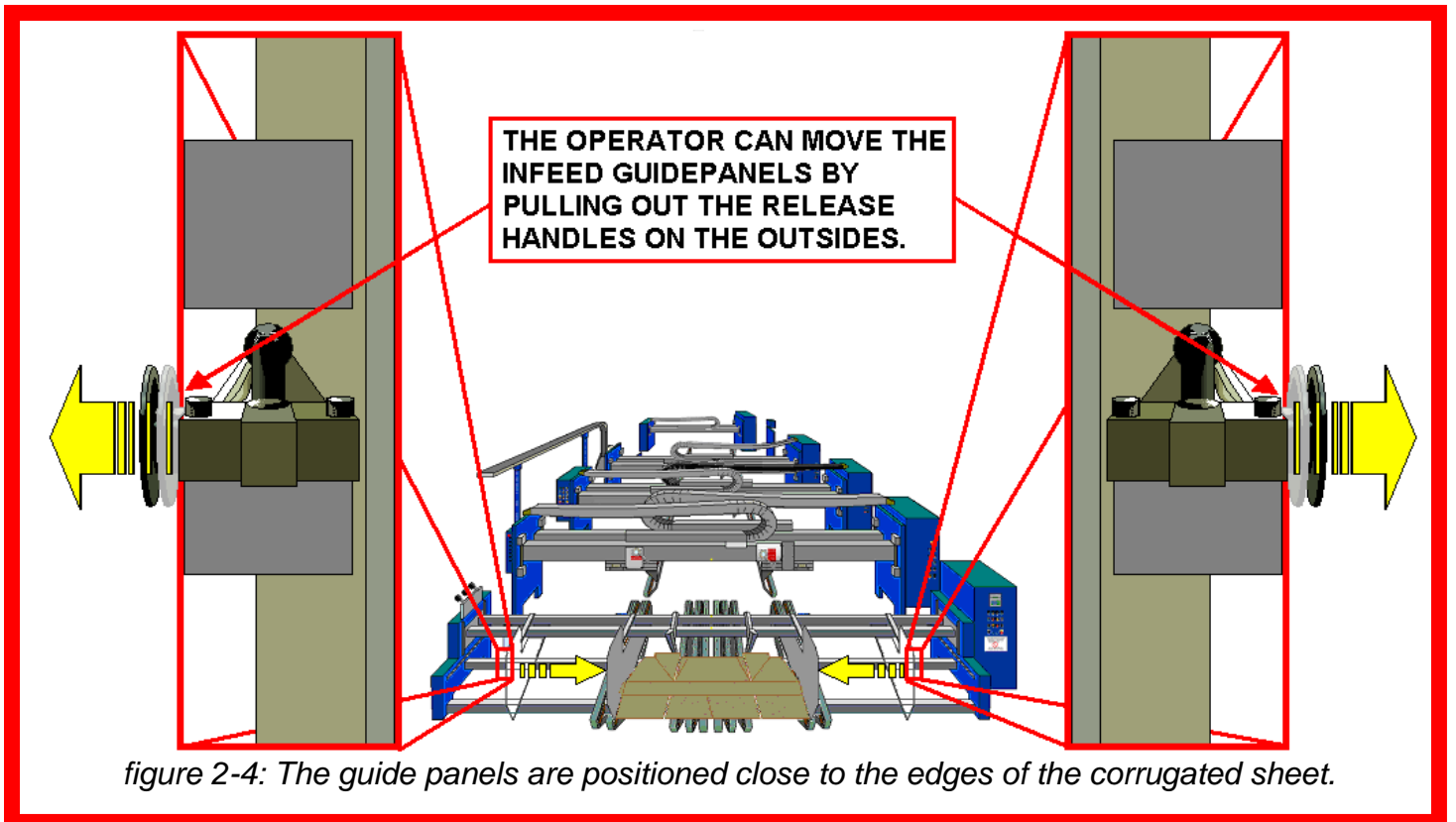

- f. The operator adjusts the

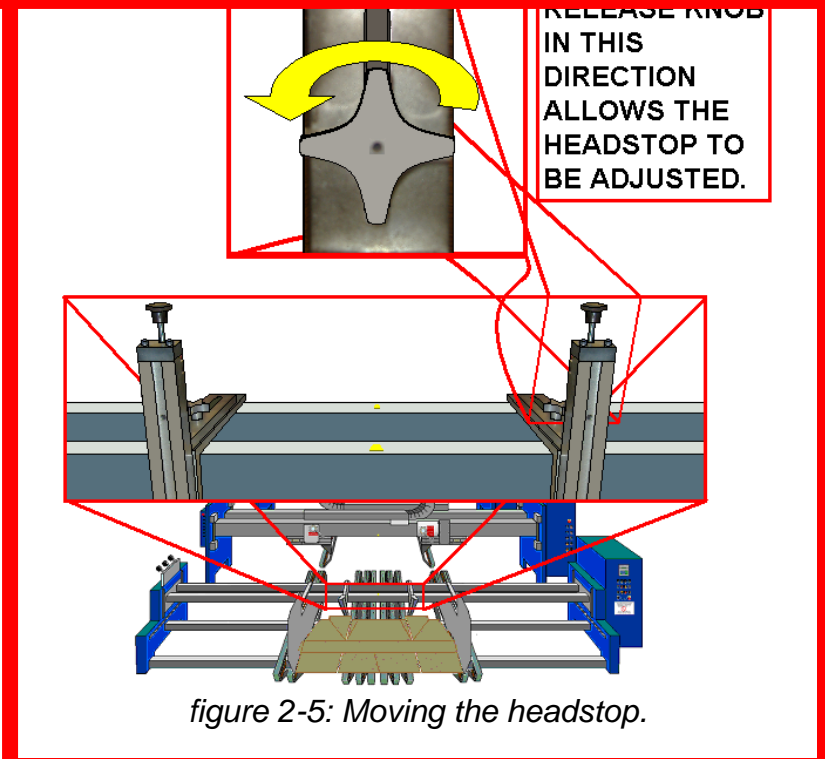

HEADSTOPS

on the
INFEED

(fig. 2-5
and 2-6).

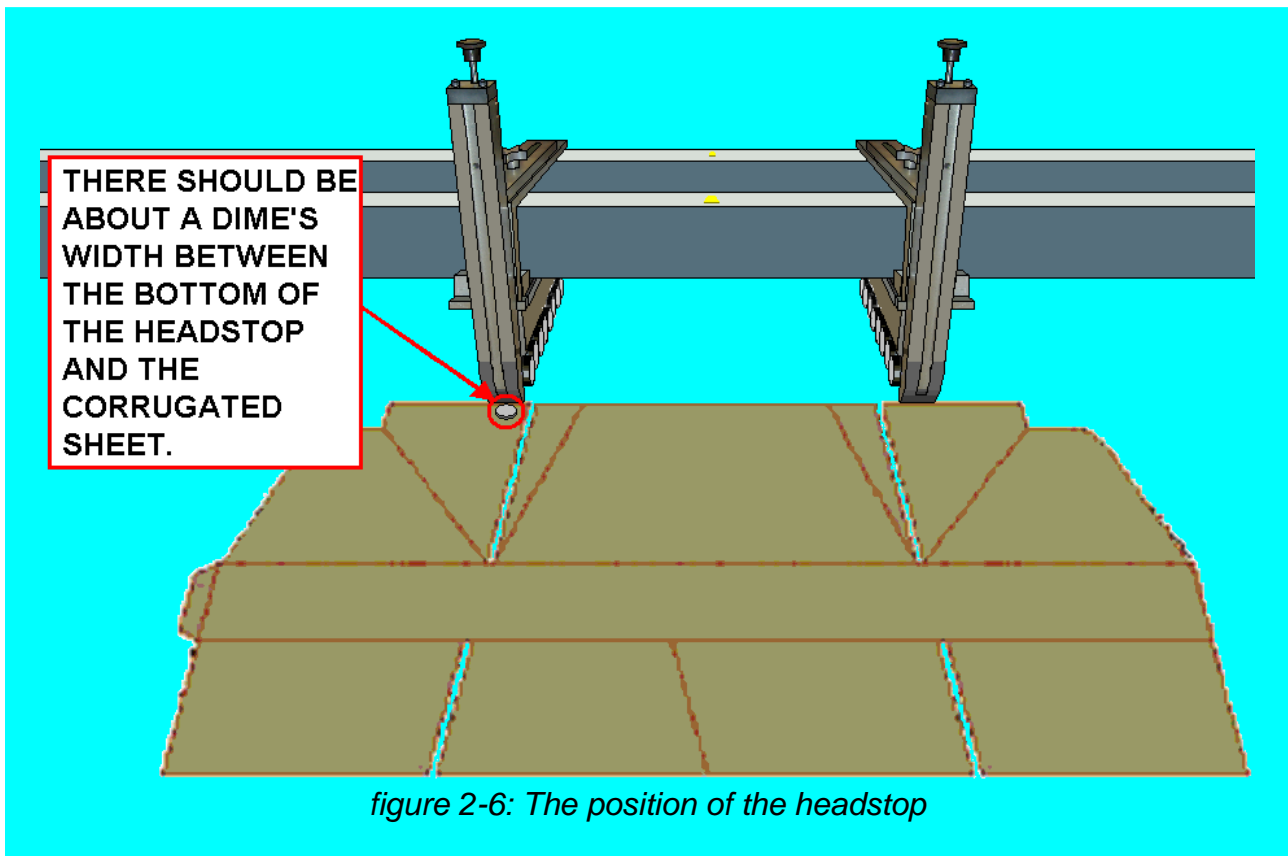

It is important that the **HEADSTOPS** be adjusted evenly to ensure the sheets of corrugated are released from the **INFEED** smoothly. If the **HEADSTOPS** are not adjusted evenly, the sheets of corrugated will be skewed as they move forward from the **INFEED** (fig. 2-7).

